

Development of a Smart Food Expiry Detection System Using Gas Sensors

Dr. G. Kalpanadevi¹, kalpanadevig.ece@krce.ac.in
Faculty, Department of ECE, K. Ramakrishnan college of engineering, Tamilnadu
Karthyayini B², Jeevasoundarya K³, Kanishca M⁴, Gopika S⁵
karthyayinibalagangatharan21@gmail.com², jeevasoundaryak@gmail.com³,
kanishcamuthiah@gmail.com⁴, gopikasenthil07@gmail.com⁵
Students, Department of ECE, K. Ramakrishnan college of engineering, Tamilnadu

Abstract: - Food waste from early or undetected spoiling is still a major worldwide issue that has a big impact on environmental sustainability, economic efficiency, and public health. Static expiry labels frequently result in the needless disposal of food or the consumption of contaminated food because they do not take dynamic storage conditions into account. We present an intelligent, real-time food expiry monitoring system that combines edge-compatible machine learning with inexpensive IoT sensing to overcome this constraint. The prototype captures spoilage indicators from common perishables like dairy and poultry by integrating temperature, relative humidity, and gas-sensitive modules that target ammonia and hydrogen sulphide. In controlled trials, a lightweight supervised model that was trained on time-series sensor data correlated with microbial growth benchmarks predicts remaining shelf life with 93.8% accuracy. In controlled trials, a lightweight supervised model that was trained on time-series sensor data correlated with microbial growth benchmarks predicts remaining shelf life with 93.8% accuracy. Our approach ensures user privacy, low latency, and offline functionality by performing inference locally on an ESP32 microcontroller, in contrast to cloud-dependent architectures. The system allows for proactive household or small-scale commercial management of food freshness by communicating alerts through a lightweight mobile interface. This study shows that condition-based expiry estimation, as opposed to calendar-based labelling, can greatly reduce preventable waste while improving consumer safety—providing a scalable, reasonably priced, and comprehensible substitute for current methods.

Key Word: IoT sensing, machine learning, real-time monitoring, temperature-humidity tracking, volatile gas analysis, edge intelligence, smart refrigeration, spoilage prediction, food expiry detection, and improved food safety.

I. INTRODUCTION

An estimated 1.3 billion tons of food—nearly one-third of all food produced for human consumption—are lost or thrown away annually worldwide. Reliance on set expiration dates that disregard current storage conditions accounts for a large amount of this waste. These printed labels frequently misrepresent actual shelf life under variable household or logistical settings because they are derived from idealized laboratory environments. [1]

As a result, consumers either throw away edible food too soon or, riskier, eat things that have already deteriorated beyond acceptable bounds. Conventional techniques for evaluating spoilage, like visual inspection, odour assessment, or pH testing, are subjective, time-consuming, and inappropriate for ongoing observation. On the other hand, new digital methods have the potential to replace calendar-based freshness estimation with condition-based freshness estimation. [2] In order to monitor microbial or chemical signs of deterioration, recent research has investigated sensor networks, electronic noses, and machine learning models.

Nevertheless, many of these systems are still limited to lab prototypes, need cloud connectivity, or are not specific enough for everyday perishables like milk, poultry, or leafy greens in home settings. In order to close these gaps, this paper presents a useful, edge-deployed food expiry detection framework that uses ambient environmental data to dynamically predict remaining shelf life. [3] Our system prioritizes time-to-expiry regression—a more useful metric for end users in contrast to earlier research that concentrated on spoilage classification. The solution provides real-time, comprehensible alerts without relying on the internet by combining inexpensive gas, temperature, and humidity sensors with a lightweight predictive model trained on microbial growth benchmarks. The architecture is feasible for both home and small-retail adoption because it places a high priority on affordability, privacy, and ease of integration into current refrigeration units.[5]

II. LITERATURE REVIEW

Over the past ten years, efforts to digitize food freshness monitoring have changed dramatically,

moving from manual inspection to embedded sensing and data-driven analytics. Early digital systems used alerts based on temperature changes. These were helpful in cold-chain logistics but didn't work well for predicting biochemical spoilage in everyday home settings. More recent works have integrated gas sensing to capture metabolic byproducts of microbial decay.[1]

As such, Nastiti et al. (2022) monitored ammonia and hydrogen sulfide emitted by chicken stored at ambient conditions, demonstrating that these gases rise predictably as spoilage progresses. The approach allowed the authors to classify freshness stages but did not translate sensor trends into a time-to-expiry estimate; these limits practical utility for consumers. In the same way, Damdam et al. (2023) used an IoT-linked electronic nose to monitor volatile organic compounds from beef and attained high accuracy in classifying spoilage. However, their system operated as a binary detector, fresh/spoiled, and did not provide detail about when spoilage would occur. [2]

Some parallel efforts have targeted storage environment monitoring: Ck et al. (2020) developed a refrigerator-integrated alert system on temperature and humidity sensors, warning the user of deviations from safe ranges. While useful, this approach assumes that the spoilage kinetics are dominated by ambient parameters alone and ignores food-specific degradation kinetics altogether.

Gillespie et al. (2023) further extended the concept to transport logistics by anomaly detection in cold-chain IoT logs, flagging temperature excursions. Although valuable in supply-chain compliance, such rule-based systems cannot adapt to individual food types or usage patterns. To work around such limitations, the researchers have turned to machine learning models trained on multi-modal sensor data.

Sahu et al., 2020, exemplified a Raspberry Pi-based framework that combined features from temperature, humidity, and images to estimate the quality of food items in a non-invasive way. [4] While promising, their system relied on cloud connectivity for model updates, which raises several concerns about reliability in general and low-connectivity households. Singha et al. (2022) proposed IntelliStore, using AI to predict storage-related spoilage in perishables. However, their focus remains on commercial warehouses rather than retrofit solutions for everyday kitchens.[5]

III. WORKING PRINCIPLE

The operating principle of the IoT-based food spoilage detector relies on the detection of volatile gases, specifically methane (CH_4), produced by the natural decomposition of perishable food items, such as fruits and vegetables. [2] With increased microbial activity during spoilage, the anaerobic metabolic processes produce measurable concentrations of methane and other volatile organic compounds. A methane-sensitive gas sensor, typically the MQ-4, is used to monitor the surrounding atmosphere in enclosed storage spaces such as refrigerators. This act based on the resistive change in its sensing layer from tin dioxide (SnO_2) due to the exposure to methane, thus converting gas concentration into a proportional analog voltage signal.[3]

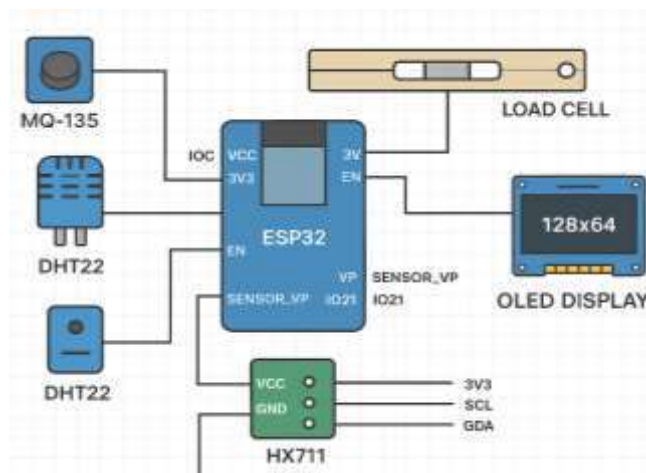

Figure: 1. Circuit diagram of the food expiry detector using IoT

The resultant signal is then fed into a microcontroller, which is often an Arduino Uno, for preprocessing according to a pre-defined threshold-based algorithm previously calibrated with known spoilage conditions. Upon exceeding the set threshold by the sensor, the system triggers localized alerts through visual means (e.g., a red LED), auditory means such as a buzzer, and textual means of an LCD display showing "SPOILED" or real-time gas levels.[4] At this time, sensor data may also be streamed to the Arduino Serial Monitor for the purpose of real-time validation and logging.[4] The autonomous functionalities of this setup preclude internet connectivity and advanced analytics and are particularly suitable for low-cost household-level deployment to prevent the accidental intake of spoiled food and reduce avoidable waste.[5]

IV. METHODOLOGY AND RESULT

The IoT-based food spoilage detection system is based on the biochemical principle that organic matter in the process of decomposition, especially fruits and vegetables, generates measurably detectable quantities of methane (CH₄) gas as a by-product of microbial metabolism in low-oxygen conditions.[1] This phenomenon is utilized through a methane-sensitive MQ-4 gas sensor, whose internal layer of SnO₂ exhibits a measurable variation in electrical resistance upon exposure to CH₄. The linear voltage signal resulting from this, proportional to the concentration, is then routed into an Arduino microcontroller where it is matched against a previously established threshold value determined through empirical calibration with known fresh and spoiled samples.[2] If the sensor reading surpasses this threshold, then the system triggers off a multi-modal alert mechanism: a red LED turns on, a buzzer sounds off an audible signal, and a 16×2 LCD shows a clear “SPOILED” status with the real-time level of methane[3]

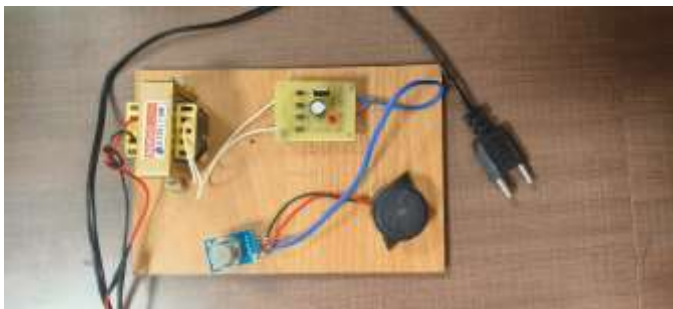

Figure: 2. Result of the Food Expiry Detector

In parallel, data is streamed to the Arduino Serial Monitor for observation and validation in a continuous manner. This setup functions autonomously in enclosed environments like household refrigerators, independent of any internet operation or computation, and hence offers a simple and fast, cost-effective early warning against accidental consumption of deteriorated food.[4]

V. CONCLUSION

In summary, the incorporation of inexpensive embedded sensors, in particular methane-detecting gas sensors like MQ-4, with microcontroller-based systems presents an extremely practical and feasible way to monitor food freshness in real time. These systems, merely through some threshold-based logic, allow biochemical signals of spoilage to be translated into actionable electronic alerts that will enable users to make timely decisions about the safety of food and how or if it should be disposed of. The prototype demonstrated here autonomously identifies the early stages of spoilage effectively within household refrigeration units through gas emissions that are well within the range of measurement, rather than relying on subjective sensory evaluation. This method not only reduces health risks from consuming spoiled food but also meaningfully contributes to reducing food waste at the household level. Future improvements might include multiple sensor fusion and enhanced selectivity in order to widen applicability to various food types. Even in this form, however, the system represents a serious advance toward smarter, safer, and more sustainable food management by consumers.

REFERENCES

- [1] B.Ravi Chander , P.A.Lovina ,G.Shiva Kumari Assistant Professors, Dept. of ECE, St.Martin’s Engineering college, Dhulapally(v), kompally ,Secunderabad 500100 Telangana
- [2] Prof. N.S. Ujgare Student, Dept. Of Information Technology, KBT College of Engineering, Maharashtra, India Assistant Professor Dept. of Information Technology, KBT College of Engineering, Maharashtra, India. International Research Journal of Engineering and Technology
- [3] D. -E. Kim, N. -D. Mai and W. -Y. Chung, "AIoT-Based Meat Quality Monitoring Using Camera and Gas Sensor with Wireless Charging," in IEEE Sensors Journal, vol. 24, no. 6, pp. 7317-7324, 15 March 2024.
- [4] C. Song, Z. Wu, J. Gray and Z. Meng, "An RFID Powered Multisensing Fusion Industrial IoT System
- [5] Nguyen TB, Tran VT, Chung WY. Pressure Measurement-Based Method for Battery-Free Food Monitoring Powered by NFC Energy Harvesting. Sci Rep.